

WESTERN PRESSURE CONTROLS 2005 LTD.

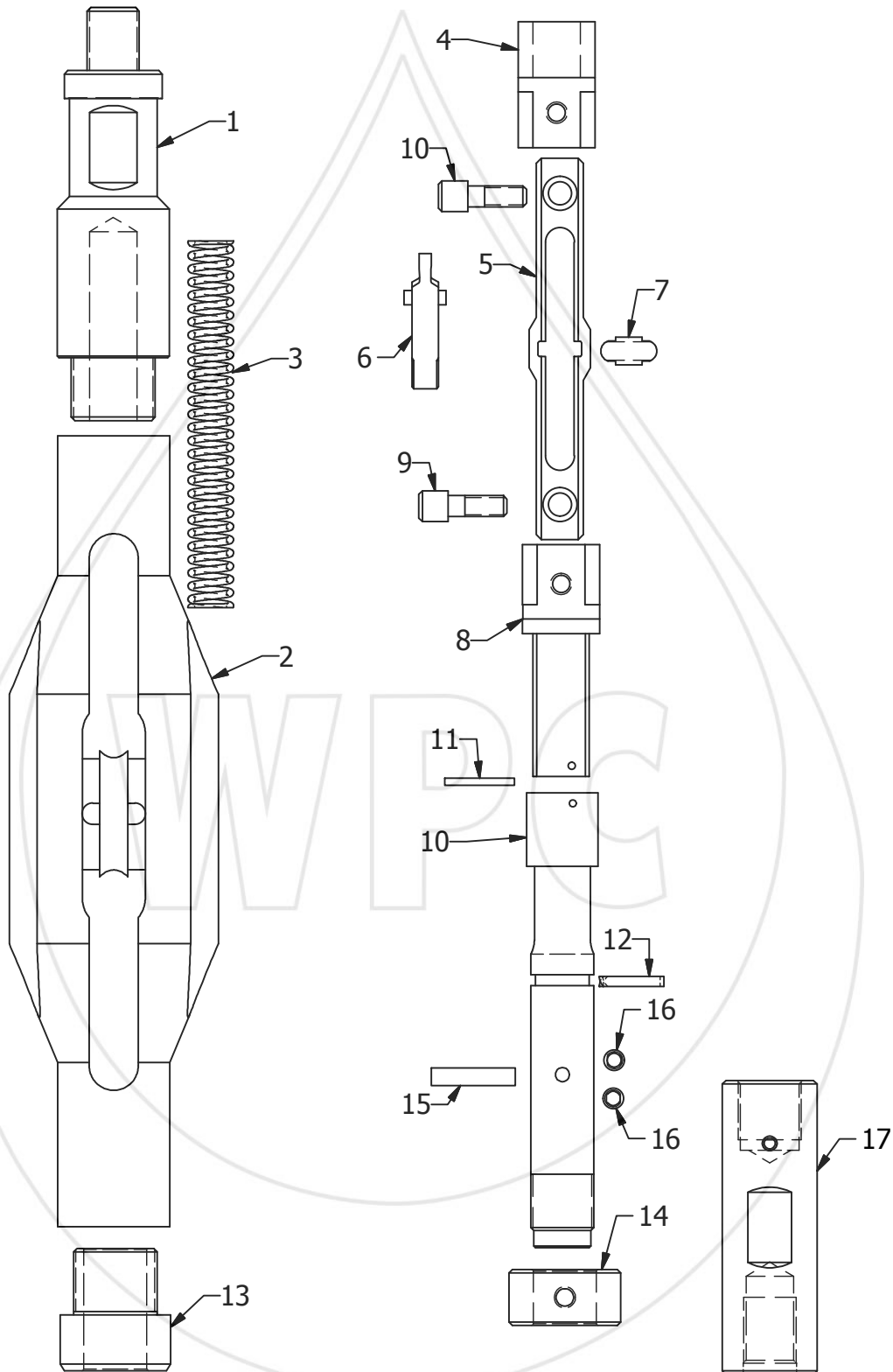

TOOL

W.P.C. MECHANICAL CAM PERFORATOR



**WESTERN PRESSURE
CONTROLS 2005 LTD.**
10021-56TH AVENUE
EDMONTON, AB, CA
PH: (780) 437-3615
FX: (780) 437-3616

www.westernpressure.com

WESTERN PRESSURE CONTROLS 2005 LTD.

W.P.C. CAM PERFORATORS

#	PART NAME	1.900"	2.375"	2.875"	3.500"	4.500"
	ASSEMBLY	H1.900CAM00	H2.375CAM00	H2.875CAM00	H3.500CAM00	H4.500CAM00
1	TOP SUB	H1.900CAM01	H2.375CAM01	H2.875CAM01	H2.875CAM01	H2.875CAM01
2	BODY	H1.900CAM02	H2.375CAM02	H2.875CAM02	H3.500CAM02	H4.500CAM02
3	PUNCH SPRING	H1.900CAM03	H2.375CAM03	H2.875CAM03	H2.875CAM03	H2.875CAM03
4	UPPER SLIDE	H1.900CAM04	H2.375CAM04	H2.875CAM04	H2.875CAM04	H2.875CAM04
5	CONTROL FRAME	H1.900CAM05	H2.375CAM05	H2.875CAM05	H2.875CAM05	H2.875CAM05
6	KNIFE	H1.900CAM06	H2.375CAM06	H2.875CAM06	H2.875CAM06	H2.875CAM06
7	PUNCH PIN	H1.900CAM07	H1.900CAM07	H1.900CAM07	H1.900CAM07	H1.900CAM07
8	LOWER SLIDE	H1.900CAM08	H2.375CAM08	H2.875CAM08	H2.875CAM08	H2.875CAM08
9	SOCKETED CAP SCREW	3/8"-16UN x 0.875	3/8"-16UN x 0.875	3/8"-16UN x 1.000	3/8"-16UN x 1.000	3/8"-16UN x 1.000
10	CONNECTOR	H1.900CAM09	H2.375CAM09	H2.875CAM09	H2.875CAM09	H2.875CAM09
11	BRASS SHEAR PIN	0.125	0.125	0.125	0.125	0.125
12	SNAP RING	H1.900CAM11	H2.375CAM11	H2.875CAM11	H2.875CAM11	H2.875CAM11
13	RETAINER PLUG	H1.900CAM10	H2.375CAM10	H2.875CAM10	H2.875CAM10	H2.875CAM10
14	SHEAR PIN COLLAR	H1.900CAM12	H2.375CAM12	H2.875CAM12	H2.875CAM12	H2.875CAM12
15	STEEL SHEAR PIN	5/16 x 1.000	5/16 x 1.188	5/16 x 1.500	5/16 x 1.500	5/16 x 1.500
16	SET SCREW	3/8-16UN	3/8-16UN	3/8-16UN	3/8-16UN	3/8-16UN
17	BOTTOM SUB	H1.900CAM13	H2.375CAM13	H2.875CAM13	H2.875CAM13	H2.875CAM13

PURPOSE:

To cut a hole in the tubing down the well to be able to access a specific area.

SPECIFICATIONS:

Multiple tool sizes to best fit current tubing size.

TOOL

**W.P.C. MECHANICAL
CAM PERFORATOR**



**WESTERN PRESSURE
CONTROLS 2005 LTD.**
10021-56TH AVENUE
EDMONTON, AB, CA
PH: (780) 437-3615
FX: (780) 437-3616

www.westernpressure.com